

REVISION HISTORY				
REV	ECO	DESCRIPTION	DATE	APPROVED
-	-	-	-	-

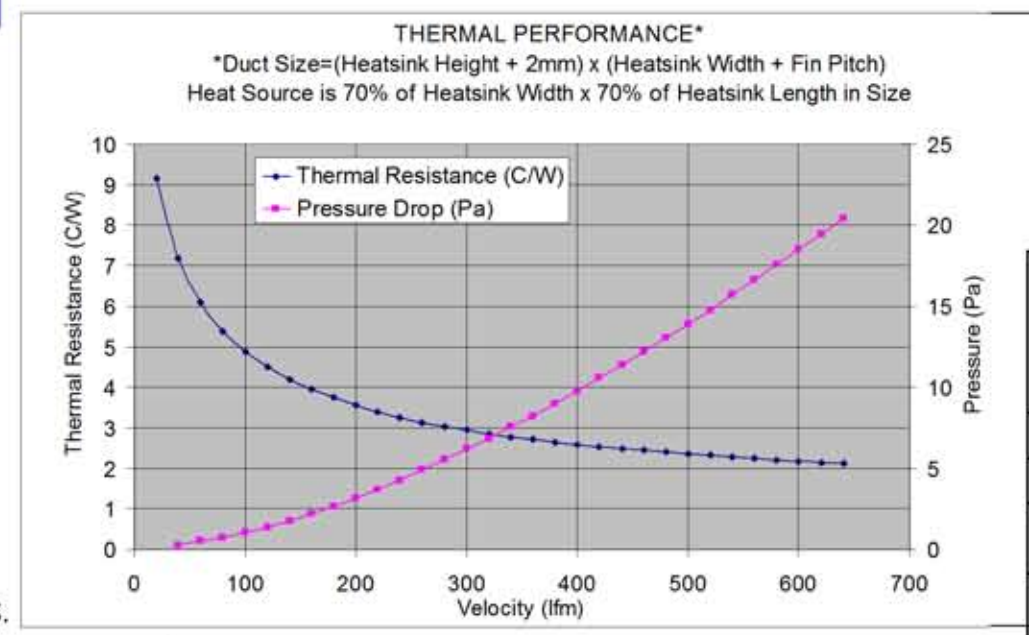
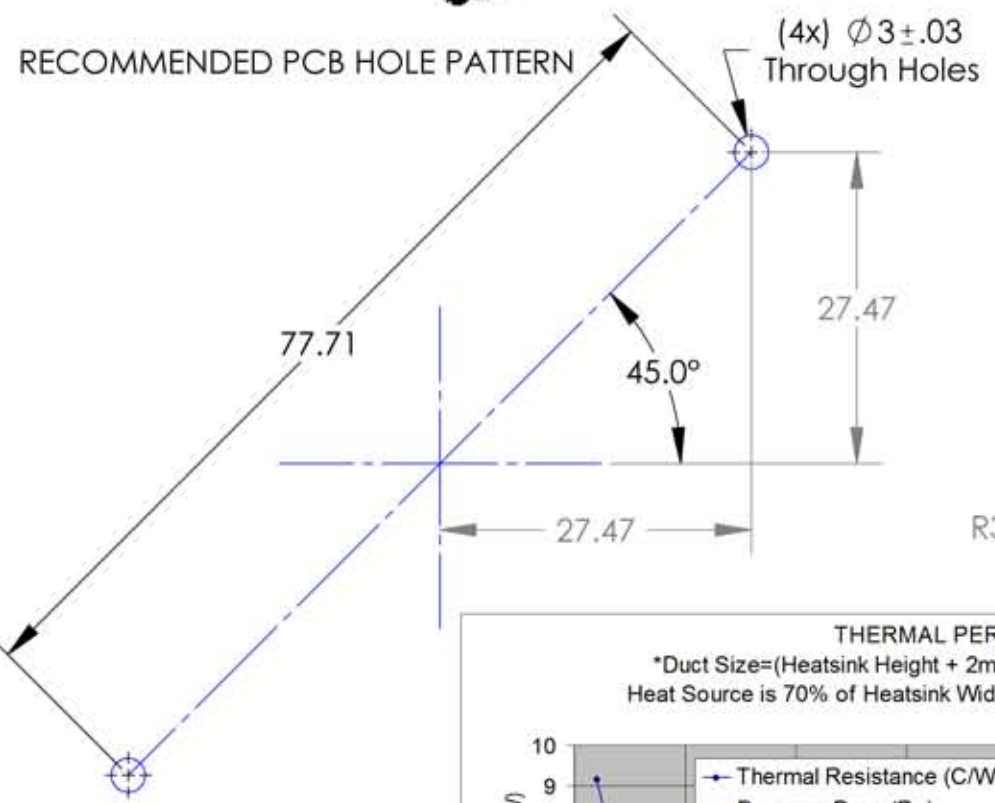
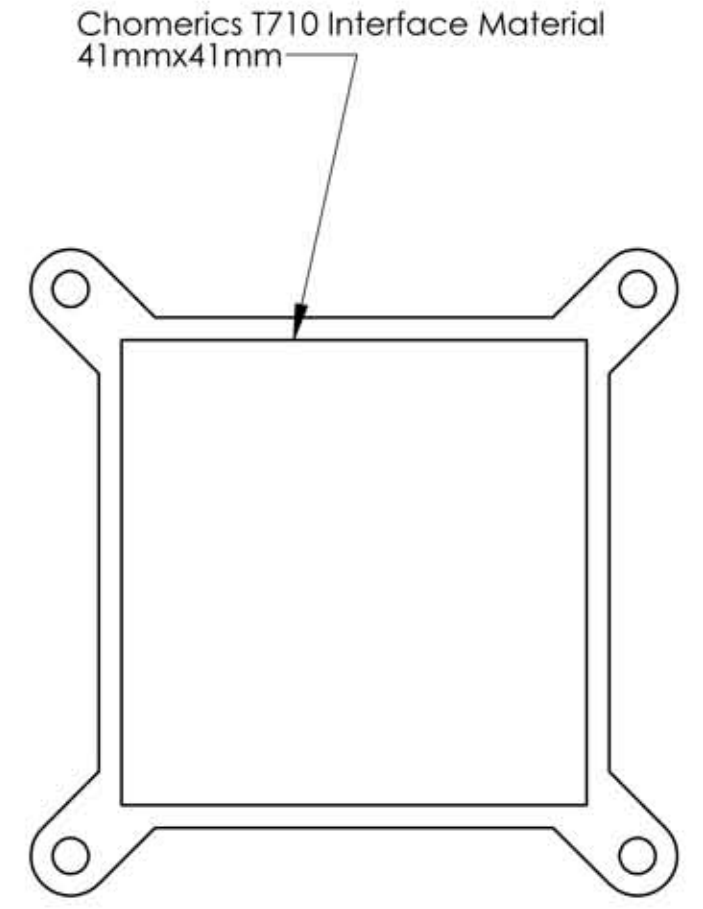
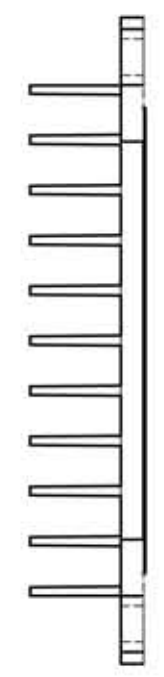
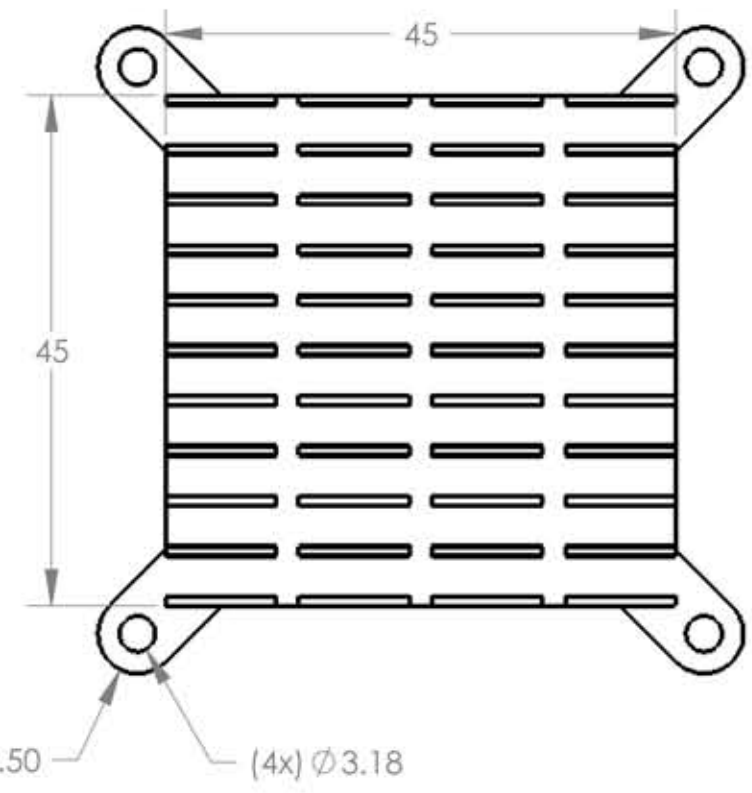
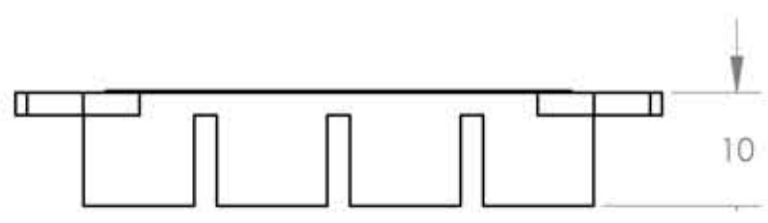
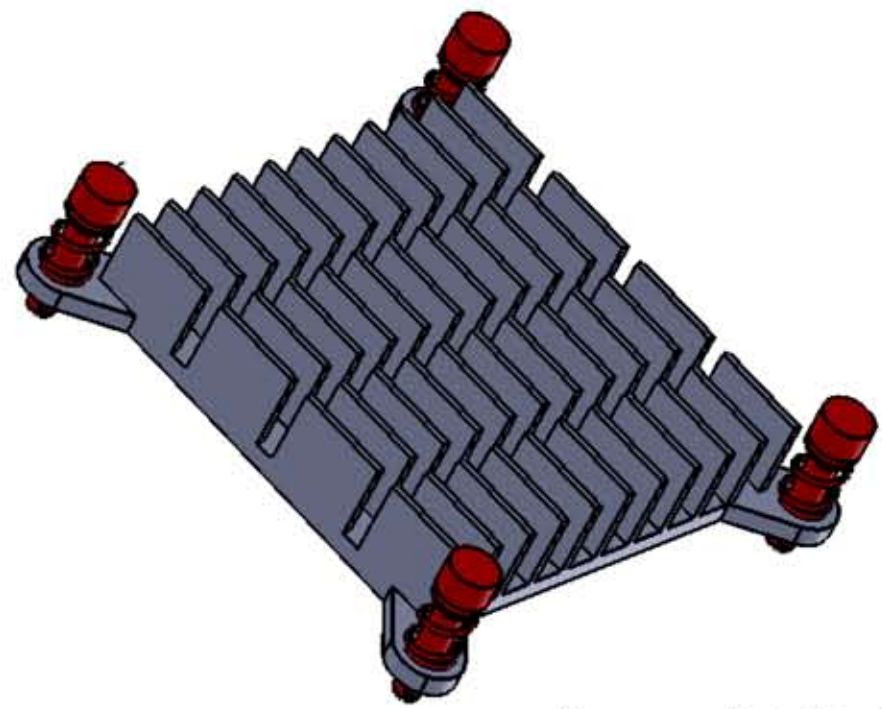

- NOTES:
1. MATERIAL: ALUMINUM 6063-T5
 2. FINISH: BLACK ANODIZE
 3. ALL TOLERANCES APPLY AFTER FINISHING.
 4. REMOVE BURRS AND BREAK SHARP EDGES.

UNLESS OTHERWISE SPECIFIED DIMENSIONS ARE IN mm TOLERANCE ARE:			DO NOT SCALE THIS DRAWING	
DECIMALS	FRACTIONS	ANGLES	APPROVALS	DATE
0-6mm $\pm .10$			E.T.	04/20/2010
6-17mm $\pm .15$			E.T.	04/20/2010
17-30mm $\pm .20$		$\pm .5^\circ$	RESP ENG	
REMOVE BURRS & SHARP EDGES			MFG ENG	
ALL MACHINED SURFACES 32			QUAL ENG	
MATERIAL	Aluminum 6063-T5		THE INFORMATION CONTAINED IN THIS DRAWING IS THE SOLE PROPERTY OF COOLING SOURCE CORPORATION. ANY REPRODUCTION IN PART OR WHOLE WITHOUT THE WRITTEN PERMISSION OF COOLING SOURCE CORPORATION IS PROHIBITED.	
FINISH	Black Anodize			

Cooling Source

SIZE	DWG NO.	REV
B	CS8674510B1	A
SCALE: 3: 2		SHEET: 1 OF 1