

4

3

2

1

NOTE: UNLESS OTHERWISE SPECIFIED

- 1. MATERIAL: COPPER
- 2. Wick Structure: Sintered
- 3. Working Fluid: Water

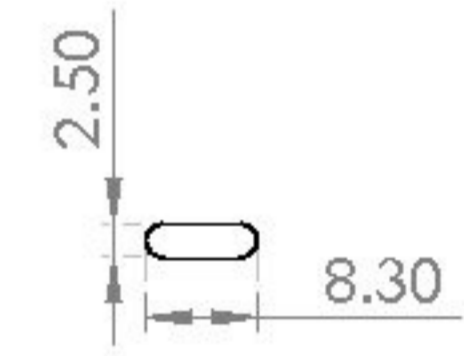
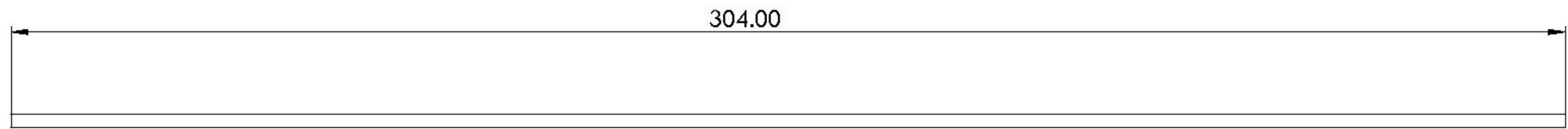
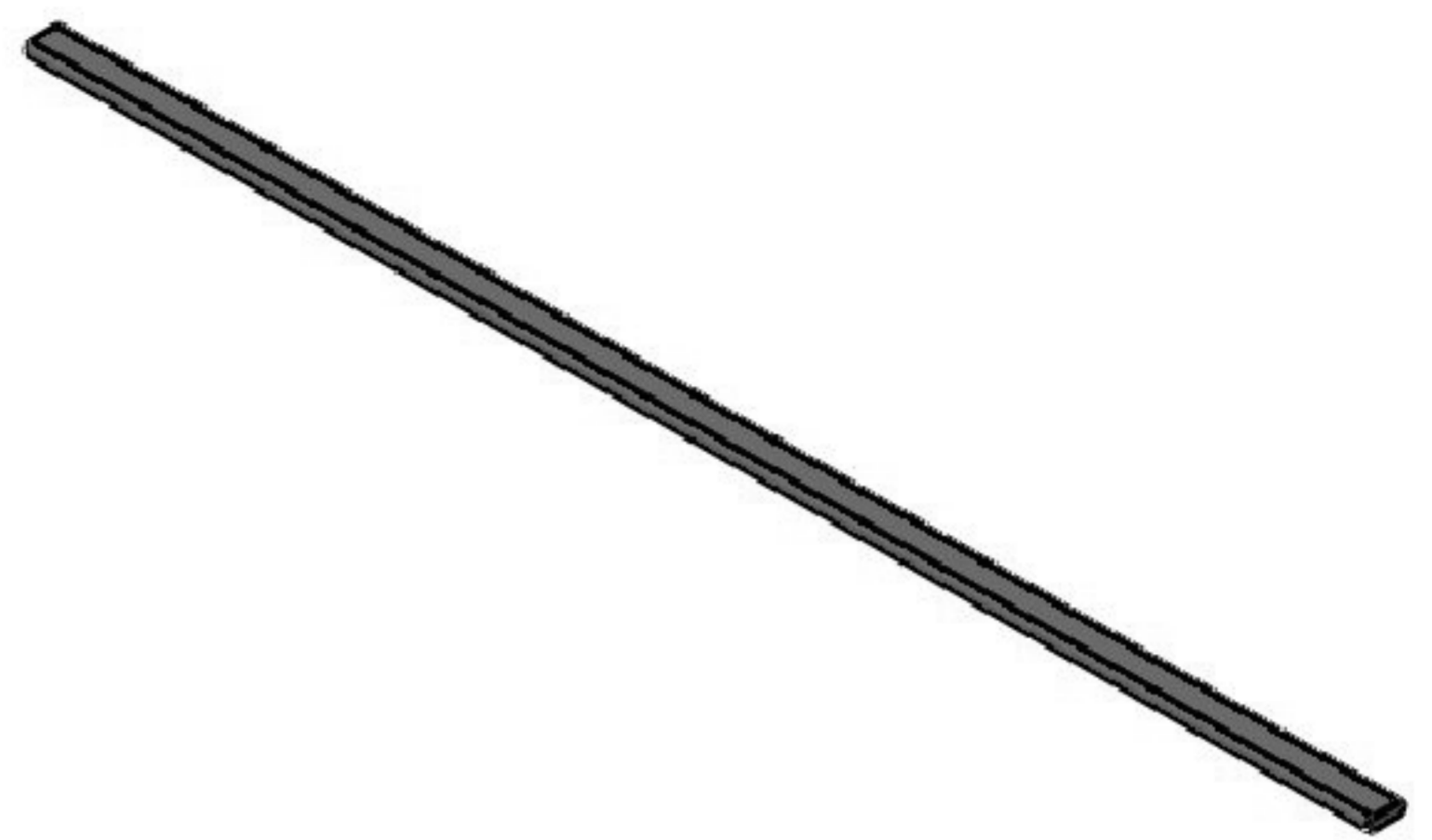

B

B

A

A

4

3

2

1

UNLESS OTHERWISE SPECIFIED: DIMENSIONS ARE IN INCHES TOLERANCES: ANGULAR: $\pm 1^\circ$ BEND \pm .X \pm .1 .XX \pm .01 .XXX \pm .005 INTERPRET GEOMETRIC TOLERANCING PER ASME Y14.5-2009 DO NOT SCALE DRAWING	DRAWN	NAME	DATE	 ERMORE CALIFORNIA
	CHECKED			
	ENG APPR.			
	PROPRIETARY AND CONFIDENTIAL THE INFORMATION CONTAINED IN THIS DRAWING IS THE SOLE PROPERTY OF COOLING SOURCE. ANY REPRODUCTION IN PART OR AS A WHOLE WITHOUT THE WRITTEN PERMISSION OF COOLING SOURCE IS PROHIBITED.			6X304mm Flat Heat Pipe
	SIZE	CS400-6304-F-OA	REV	
	SCALE: 1:2			SHEET 1 OF 1