

4

3

2

1

REVISION HISTORY				
REV	ECO	DESCRIPTION	DATE	APPROVED
-	-	-	-	-

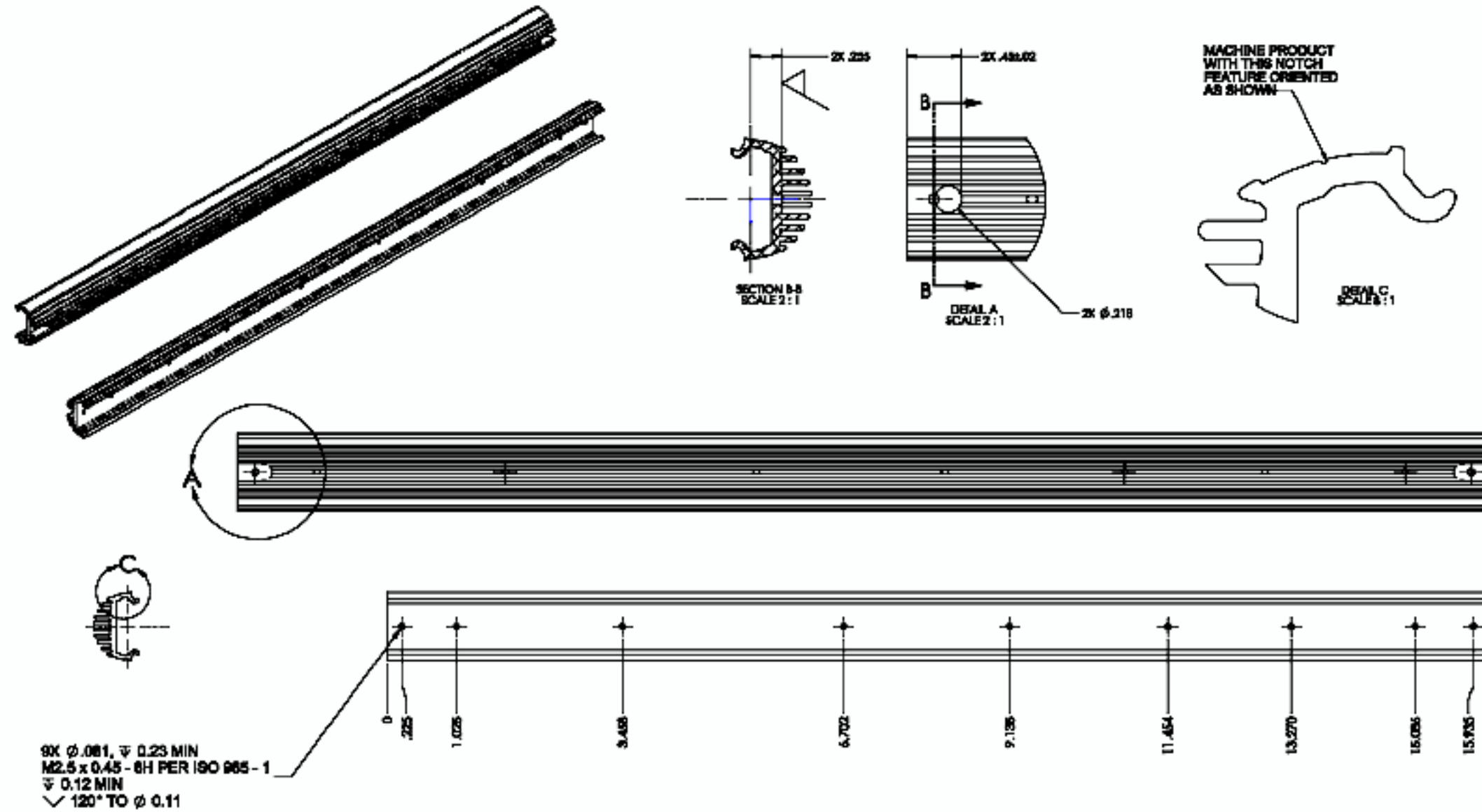

- NOTES:
1. MATERIAL: PLATE, ALUMINUM, 6061-T6.
 2. FINISH: NONE.
 3. ALL TOLERANCES APPLY AFTER FINISHING.
 4. REMOVE BURRS AND BREAK SHARP EDGES.
 5. IDENTIFY PART BY BAG AND OR BOX MARKED WITH THE PART NUMBER AND REVISION. DO NOT MARK PART.

Cooling Source Confidential



-CS504-191-A-0A

UNLESS OTHERWISE SPECIFIED DIMENSIONS ARE IN mm TOLERANCE ARE:	DO NOT SCALE THIS DRAWING	
	APPROVALS	DATE
DECIMALS	FRACTIONS	ANGLES
.X ±.10		±.5°
.XX .05		
REMOVE BURRS & SHARP EDGES		
ALL MACHINED SURFACES		32
MATERIAL		
FINISH		
THE INFORMATION CONTAINED IN THIS DRAWING IS THE SOLE PROPERTY OF COOLING SOURCE CORPORATION. ANY REPRODUCTION IN PART OR WHOLE WITHOUT THE WRITTEN PERMISSION OF COOLING SOURCE CORPORATION IS PROHIBITED.		

SIZE	DWG NO.	REV
B		
SCALE: 1:1		SHEET: 1 OF 1

4

3

2

1